

Another Way of Heating

DIRECT STEAM INJECTION OF SOLIDS OFFERS ADVANTAGES THAT CAN INCLUDE LOWER CAPITAL COST, HIGHER ENERGY EFFICIENCY AND LOWER MAINTENANCE

By Bruce Cincotta

Direct steam injection (DSI) is an emerging technology for municipal biosolids heating, especially in processes that use anaerobic digestion.

DSI has a long track record in challenging slurry heating applications. Steam is readily available and can be inexpensive to produce. Scaling from small to large flows with steam is effective and reliable. When applied correctly, DSI provides significant process benefits and overcomes a number of limitations that go with conventional solids heating methods.

HEATING IN ANAEROBIC DIGESTION

Most wastewater treatment plants with flows above 5 mgd use anaerobic solids digestion. Microbes in the digester break down the organic material, producing methane that can be captured to power boilers and electric generator sets.

Unlike aerobic digestion, which operates at ambient conditions, anaerobic digestion operates at higher temperatures to stimulate microbial activity and accelerate the biological process. To achieve higher operating temperatures, heat must be added to the process, and the temperature of the digester must be maintained.

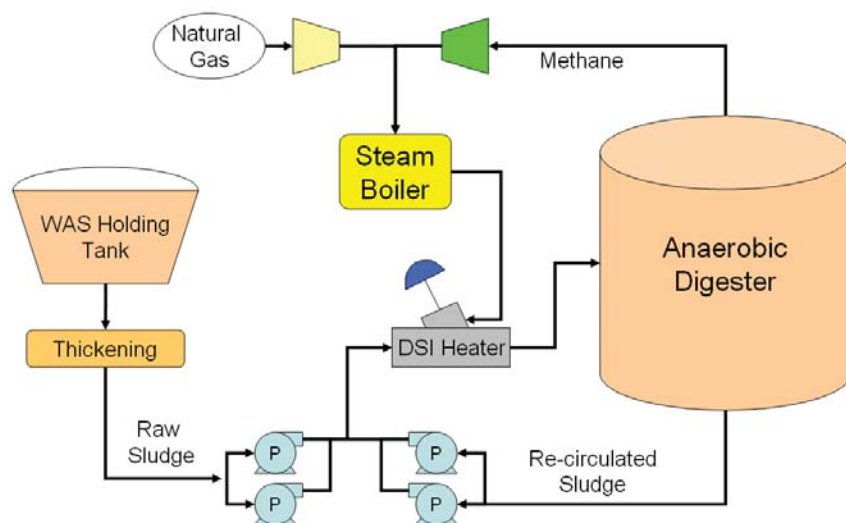

Diagram of an anaerobic digestion process with DSI heating. Anaerobic digestion operates at higher temperatures than aerobic digestion to stimulate microbial activity and accelerate the biological process. To achieve higher operating temperatures, heat must be added to the process, and the temperature of the digester must be maintained.

The operating temperature balance is critical for sustaining the correct biological environment in an anaerobic digester. Both acid former and methane former microbes optimize their processing capacity at stable temperatures. Mesophilic digestion is optimum at 95 degrees F and thermophilic digestion at 131 degrees F.

Precise temperature control provides the ideal environment. Solids can be heated before delivery to the digester and then recirculated through a heater to maintain the ideal processing temperatures.

One challenge present when heating municipal solids is the heat-sensitive nature of the material. The media used in solids heating generally is limited to 150 degrees F to avoid scorching and fouling. Municipal solids also tend to have high viscosity, which can cause large pressure drops and put excessive demand on feed pumps. Higher-viscosity solids also make it challenging to provide uniform heating, free of hot spots.

HOW DSI WORKS

Early attempts at DSI heating in anaerobic digestion commonly used steam sparge devices, which have a fixed steam exit area and use an external control valve to adjust the steam flow. These systems experienced problems with hammer and vibration, leading to unstable operation and poor temperature control.

One key factor in successful DSI is to maintain high steam velocity for effective mixing and condensation of the steam into the solids. High velocity is maintained by altering the exit area of the steam, rather than adjusting the steam pressure, to adjust steam mass flow. This approach is known as internal modulation to achieve choked flow.

Choked flow is the phenomenon of accelerating a vapor to sonic velocity by creating a pressure differential through an engineered nozzle. When choked flow is established, the steam mass flow can be metered to precisely control the heating of the slurry. This produces predictable results based on the position of the stem-plug.

Through a variable-area steam diffuser, steam flow is metered at the point where steam and liquid first contact and mix. This method

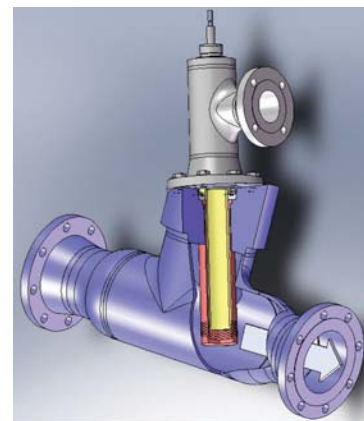

Diagram of an inline direct steam injection (DSI) sludge heater.

Efficiency	90%				
Duty	95%	0.08 \$/KW-h		0.1 \$/KW-h	
Horsepower	KW	\$/d	\$/y	\$/d	\$/y
1	0.8	1.51	552	1.89	690
2	1.6	3.02	1,103	3.78	1,379
3	2.4	4.53	1,655	5.67	2,069
4	3.1	6.05	2,206	7.56	2,758
5	3.9	7.56	2,758	9.45	3,448
7.5	5.9	11.33	4,137	14.17	5,171
10	7.9	15.11	5,516	18.89	6,895
15	11.8	22.67	8,274	28.34	10,343
20	15.7	30.23	11,032	37.78	13,790
25	19.7	37.78	13,790	47.23	17,238
50	39.4	75.56	27,581	94.46	34,476
75	59.0	113.35	41,371	141.68	51,714
100	78.7	151.13	55,162	188.91	68,952
200	157.4	302.26	110,324	377.82	137,905

The lower pressure drop (typically 1-2 psig) across a DSI heater translates into reduced demand on system pumps. This table shows typical costs for electric motor use. DSI heaters may lower the horsepower requirements by more than 50 percent when compared to multiple heat exchangers in series. DSI heating also transfers 100 percent of the heat energy into the material.

eliminates the need for an external steam control valve or downstream mechanical mixing devices.

SELECTING A DSI HEATER

In choosing a DSI heater for solids, the first and most important factor is the need for a differential between the steam pressure and the liquid pressure. DSI heater operation is optimized by maintaining high steam velocity to drive the condensation of the steam and transfer energy in a stable and rapid manner. The pressure differential determines the velocity of the steam.

Steam injectors that use an external steam-pressure regulating valve need to operate with the liquid pressure at less than 60 percent

DSI has a long track record in challenging slurry heating applications. Steam is readily available and can be inexpensive to produce. Scaling from small to large flows with steam is effective and reliable.

of the absolute steam pressure. In externally controlled heaters, the steam pressure is substantially reduced through the steam-control valve, so the available steam pressure is much lower than the design pressure. Reduction of the steam pressure also reduces steam velocity, leading to poor steam condensation and process upsets.

A second critical factor is to maintain a minimum differential between the steam pressure and the liquid pressure. This condition presents fewer process upsets, leading to more stable DSI heater operation (free of hammer and vibration), better pump integration, and improved temperature control. All these can be optimized by maintaining high-velocity steam injection to promote rapid and complete steam condensation.

A jet diffuser heater design using internal steam control allows the steam and liquid pressures to be much closer while still providing high-velocity steam injection. The ability to operate with liquid pressures up to 80 percent of the absolute steam pressures allows for stable operation across a wide operating range, minimizing process upsets.

There are a variety of ways to achieve the desired condition in real-world applications. The first is to choose a steam supply of sufficient pressure to meet the requirements. The second is to reduce the liquid pressure by moving the heater to a higher elevation, trimming the pump impellers, or changing the pressure settings in the control loops — or some combination of these.

Another essential factor for DSI heating is maintaining high-velocity steam (<1,000 fps ideal) for rapid condensation. Steam velocity is a result of the steam/liquid pressure differential. The proper steam jet characteristics also greatly influence steam condensation and help prevent hot spots in the slurry. Proper sizing is important for smooth operation. Finally, mechanical mixers to blend steam and fluid are not practical because uncondensed steam bubbles are too small to be impacted by a mechanical mixer.

BENEFITS OF DSI HEATING

Direct steam injection heating can overcome a number of limitations and process restrictions common in solids heating methods, such as those that use heat exchangers. The advantages include:

Precise temperature control. Steam is dispersed uniformly at high velocities into the solids. This provides instantaneous heat transfer in a single pass with precise temperature control to plus or minus 1 degree F without the need for an external steam-control valve.

No plugging or fouling. DSI heaters have no hot surfaces to initiate scorching of the material. This eliminates plugging and fouling, which is common in heat exchangers that use tubes or channels. That in turn means lower maintenance and greater reliability.

Lower capital investment. The physical size reduction going from a heat exchanger to a DSI heater can be significant. A 20-to-1 reduction in space requirements is not uncommon. No space is required for the removal of heat exchanger tubes, and the DSI heater can also be installed in the piping framework without the need for dedicated floor space or a foundation.

Energy savings. The lower pressure drop (typically 1-2 psig) across a DSI heater translates into reduced demand on system pumps. The accompanying table shows typical costs for electric motor use. DSI heaters may lower the horsepower requirements by

more than 50 percent when compared to multiple heat exchangers in series. DSI heating also transfers 100 percent of the heat energy into the material.

Minimized flow disruption. An in-line design DSI heater can maintain the proper flow velocities and provide minimal hang-up points for fibrous rag-type materials.

Successful sludge heating using DSI is an attainable goal with proper planning and wise use of available resources. DSI heating can be integrated with an anaerobic process reliably and with predictable results. Installation can be done in existing sludge feed or recirculation lines.

DSI is a viable alternative for wastewater treatment plants seeking to optimize the anaerobic digestion process.

Bruce Cincotta, MEng, is chief technical officer and co-owner of ProSonix LLC, a company that specializes in solving difficult process-heating problems. He can be reached at 800/849-1130 or info@pro-sonix.com. tpo